

Maths Skills for A-Level Physics

I have written this document to try and help the maths skills and confidence of those of you taking A-Level physics but not A-Level Maths. You can do well in physics without also studying maths but you will not be surprised to learn that you will encounter maths in every single physics lessons and so you should be prepared with the tools necessary to handle this.

I have tried to explain the necessary concepts and give a few worked examples in each case. This is then followed by some exercises for you to test your understanding. Answers are provided at the end.

Truth be told, much of the maths you need in A-level physics is only really GCSE standard. It is just presented in more unfamiliar and difficult contexts than you will have seen at GCSE. In places though it does push in to A-Level standard and so hopefully this document and any additional instruction from your teacher when you study these areas will enable you to cope.

Please let me know if you spot any errors or can suggest any improvements. I hope it proves useful.

Mr C

Powers

3^2 is read as “three squared” or “three to the power two”. It means to take the number it means to take the number three and multiply it by itself.

$$3^2 = 3 \times 3 = 9$$

Similarly

$$3^3 = 3 \times 3 \times 3 = 27$$

And so on. This is easy to do in your head but quickly becomes harder when the numbers become awkward decimals or the powers become very large. For instance, good luck doing this one in your head.

$$2.534577^{6.5}$$

You now need to use your calculator. Make sure you are confident in doing this.

$$2.534577^6 = 169.9176063$$

Some powers are not neat whole numbers (integers). Even though you will be using calculators most of the time you should still know what the symbols are actually asking you to do. To start with what about if the power is a negative number?

$$x^{-a} \text{ means } \frac{1}{x^a}$$

So for instance

$$2^{-3} = \frac{1}{2^3} = \frac{1}{8} = 0.125$$

What if the power is a fraction (i.e a number between zero and one)?

$$x^{\frac{1}{a}} \text{ means } \sqrt[a]{x}$$

That is we take the “ath root of x”. So for instance

$$16^{\frac{1}{4}} = \sqrt[4]{16} = 2$$

What about a negative fraction!

$$x^{-\frac{1}{a}} \text{ means } \frac{1}{\sqrt[a]{x}}$$

Or “one over x to the ath root”. For example

$$4^{-\frac{1}{2}} = \frac{1}{\sqrt[2]{4}} = \frac{1}{2} = 0.5$$

We can also combine powers if we are multiplying or dividing the same number raised to different powers.

$$x^a x^b = x^{a+b} \text{ and } \frac{x^a}{x^b} = x^{a-b}$$

Remember this only works if x is the same number throughout. Three more “power” rules which come up more rarely are:

$$x^{\frac{a}{b}} = \sqrt[b]{x^a} \text{ and } x^{-\frac{a}{b}} = \frac{1}{\sqrt[b]{x^a}} \text{ and } (x^a)^b = x^{ab}$$

Exercises

Evaluate the following

1. 2^4
2. 5^{-2}
3. $1.5^{1.5}$
4. $64^{\frac{1}{2}}$
5. $64^{-\frac{1}{2}}$
6. $a^4 a^6$
7. $\frac{z^6}{z^2}$
8. $(y^{0.5})^{0.5}$

Standard Form

Physics involves measuring and performing calculations with very big and very small numbers. For instance the charge on one electron (in Coulombs) is 0.00000000000000000016 C.

Or the average distance between the Earth and the Sun (in metres) is 150000000000 m.

Clearly writing down these numbers time after time soon becomes tedious and error prone.

Instead then we use standard form (sometimes called scientific notation) to represent very large and very small numbers in a more compact form.

$$a \times 10^b$$

Here we the convention is that “a” is a number between one and ten and “b” is any integer (positive or negative). You must get used to seeing this as just one entity and not a calculation that actually needs to be worked out.

Let’s say we wish to represent 15000000000 m in standard form. We imagine the decimal place after the last zero and begin to move it to the left counting how many times we have to move it until we get to a number between one and ten.

In this case if we move the decimal place to the left we eventually reach 1.5000000000 which is between one and ten. To do this we had to move the decimal place 11 digits to the left so finally:

$$15000000000 = 1.5 \times 10^{11}$$

What about 0.00000000000000000016 C? Here, to get to a number between one and ten we have to move the decimal place to the right. Eventually we will get to 1.600000000000000000 C. We had to move the decimal place 19 spaces to get here. The difference is we had to move it to the right rather than the left. So we add a minus sign on the power in the standard form notation.

$$0.00000000000000000016 = 1.6 \times 10^{-19}$$

The rule is that positive powers on the x10 bit means big numbers and negative powers on the x10 bit means numbers less than one. We can also add a negative sign on the front of the standard form to indicate really big and really small negative numbers.

Some standard form powers are so common that they get their own name. You have likely encountered many of them before. For instance:

$$1000 \text{ m} = 1 \times 10^3 \text{ m} = 1 \text{ kilometre}$$

$$0.001 \text{ m} = 1 \times 10^{-3} = 1 \text{ millimetre}$$

Here is a table of the ones you need to learn. You will notice the powers are all multiples of three.

Prefix	pico-	nano-	micro-	milli-	kilo-	mega-	giga-	tera-
Value	10^{-12}	10^{-9}	10^{-6}	10^{-3}	10^3	10^6	10^9	10^{12}
Prefix symbol	p	n	μ	m	k	M	G	T

You also need to be confident in typing these numbers in to your calculator. Do not use the $x^()$ button up near the top of the calculator. You need to use the $x10^x$ button down on the bottom row of the calculator to do the power bit of the standard form number. Remember your calculator (correctly) treats the standard form as one number so there is no need to put it in brackets.

Exercises

Write these numbers in standard form.

9. 2000
10. 2500
11. 0.0002
12. 0.00025

Write these standard form numbers as “normal numbers”.

13. 1×10^5
14. 1.56×10^5
15. 1×10^{-5}
16. 1.56×10^{-5}

Covert these prefixed quantities.

17. 1500 m as km
18. 12000 g as kg
19. 6 m as mm
20. 6 μg as g

Orders of Magnitude

When we are performing calculations with standard form remember we need to treat the standard form as one entity and use the correct button on the calculator to enter them. Leave your answers as standard form wherever possible. Try this one on your calculator and make sure you get the correct answer.

$$\frac{6.67 \times 10^{-11} \times 5.947 \times 10^{24}}{6.37 \times 10^{12}} = 62.27$$

You should be able to estimate the answers to standard form calculations in your head. It's not as bad as it sounds! This is called “orders of magnitude” estimation and could save you from making a howler of an error in an exam.

When we multiply two standard form numbers we multiply the “normal” numbers and add the “powers”.

$$2 \times 10^5 \times 3 \times 10^4 = 6 \times 10^9$$

For dividing we have to divide the “normal” numbers then subtract the “powers”

$$8 \times 10^{10} \div 4 \times 10^7 = 2 \times 10^3$$

Note that sometimes the “normal” part of the answer will stray out from in between one and ten so we have to adjust the power to bring it back in line with convention.

$$5 \times 10^4 \times 3 \times 10^3 = 15 \times 10^7 = 1.5 \times 10^8$$

We could try and do a quick orders of magnitude estimate on the calculation at the beginning of this section.

$$\frac{6.67 \times 10^{-11} \times 5.947 \times 10^{24}}{6.37 \times 10^{12}} \approx \frac{7 \times 10^{-11} \times 6 \times 10^{24}}{6 \times 10^{12}} \approx \frac{42 \times 10^{13}}{6 \times 10^{12}} \approx 7 \times 10^1 \approx 70$$

This is in the right area as the real answer so we can have some confidence we have done it right!

One last thing. Despite the convention that the “normal” number in standard form should always be between one and ten physicists often ignore this!

The reason is that it makes comparing two numbers much easier if the “powers” part is the same, equivalent to the prefixes being the same on the numbers. If we have the numbers 2×10^4 and 5×10^4 we can easily see the second is bigger.

However if we have the numbers 5×10^4 and 2×10^5 it could be a little harder to spot which is bigger. Especially if you are working under pressure. To get around this we could write them with the same power part, 5×10^4 and 20×10^4 . Direct comparison shows us that the second number is bigger again here.

A place this is commonly used in physics is in quoting wavelengths of physical light. They are all given in nanometres to make their relative sizes easier to compare.

Color	Wavelength
Violet	380–450 nm
Blue	450–495 nm
Green	495–570 nm
Yellow	570–590 nm
Orange	590–620 nm
Red	620–750 nm

Exercises

21. $\frac{5.57 \times 10^{-15} \times 8.98 \times 10^{20}}{(2.52 \times 10^8)^2} = ?$

22. Without using a calculator. Is this calculation correct? $5 \times 10^4 \times 1.5 \times 10^3 = 7.5 \times 10^1$

23. Without using a calculator. Is this calculation correct? $6 \times 10^8 \div 1.5 \times 10^3 = 4 \times 10^5$

24. Which is bigger, 600 μm or 0.06 mm?

Algebra (re-arranging equations)

There are **lots** of equations in A-level physics. Some of them containing many terms and many operations. Take this one for example. It is used in special relativity to work out the “dilated time” of a particle moving near the speed of light.

$$t = \frac{t_0}{\sqrt{1 - \frac{v^2}{c^2}}}$$

This is an extreme example and it’s not important at this stage what any of these symbols mean but you just need to be aware that you may need to re-arrange this to make “v” the subject for example.

Let’s go over the rules for re-arranging. Essentially we must perform a set of operations to “undo” everything that has been done to the symbol we want on its own. We must remember to perform the operations on both sides of the equals sign and they should be the opposite (strictly speaking it is the inverse) of what is currently operating on the symbol we wish to isolate.

Let’s say we want “I” on its own in the following.

$$V = IR$$

The “I” is currently being multiplied by R, which we don’t want. To undo a multiplication we must divide. So:

$$\frac{V}{R} = \frac{IR}{R}$$

The Rs on the right hand side cancel to leave.

$$\frac{V}{R} = I$$

What about this one let's say we want " ω " on its own. Again, it's not important what any of these symbols actually stand for right now.

$$E_k = \frac{1}{2}I\omega^2$$

Multiply both sides by 2 to get rid of the half.

$$2E_k = I\omega^2$$

Now divide by " I "

$$\frac{2E_k}{I} = \omega^2$$

Now square root both sides to get rid of the squared.

$$\sqrt{\frac{2E_k}{I}} = \omega$$

Done. Remember to take your time and be systematic. This is an area of maths where realistically the only way to get better is to just do loads of practice. With that in mind.....

Exercises

25. Make "B" the subject. $F = BIL$
26. Make m_1 the subject. $F = \frac{Gm_1m_2}{r^2}$
27. Make r the subject. $F = \frac{Gm_1m_2}{r^2}$
28. Make v the subject. $t = \frac{t_0}{\sqrt{1-\frac{v^2}{c^2}}}$

Pythagoras Theorem

This comes up a lot in A-level physics. There is nothing really new to add except that you may have to apply it in strange and unfamiliar contexts. Be on the lookout for right angled triangles!

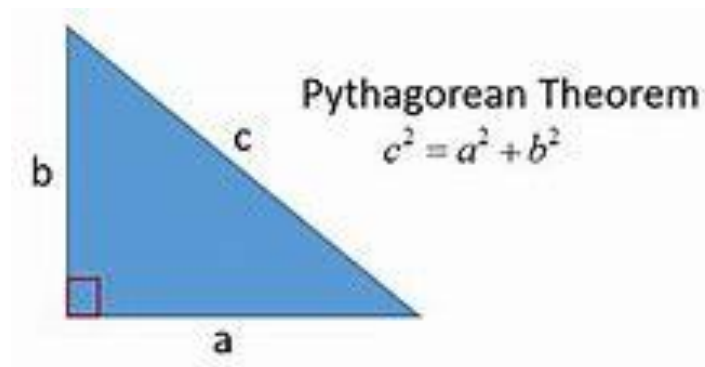

Lets say we have two vectors at right angles. We can draw on the resultant vector and use pythagoras to work out the magnitude (size) of the resultant force. Here are two forces acting on an object at right angles. We can draw on the resultant and this makes a right angled triangle.

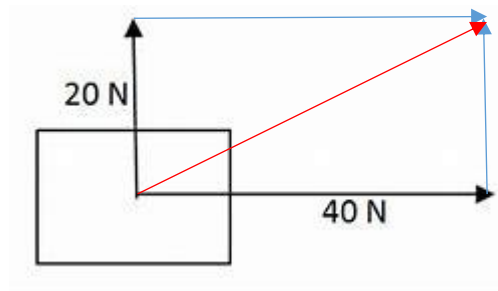

The resultant is the red arrow and it makes a right angled triangle with one of the black arrows and the coresponding blue arrow. Thus we can use pythagoras. We wish to find the hypotenuese with one side 20 and the other 40.

$$F = \sqrt{20^2 + 40^2} = 44.7N$$

Exercises

29. If $a^2 = b^2 + c^2$ re-arrange to make b the subject. Then make c the subject.
30. Calculate the length of the hypotenuse if the other two sides are 20 cm and 30 cm.
31. If the hypotenuse of a right angled triangle is 500 N and one other side is 400 N calculate the length of the other side.

Trigonometry

Again this is mostly just GCSE standard sin, cos and tan with one extra addition. Remember the basic trigonometry functions work on right angled triangles only. Here is a reminder.

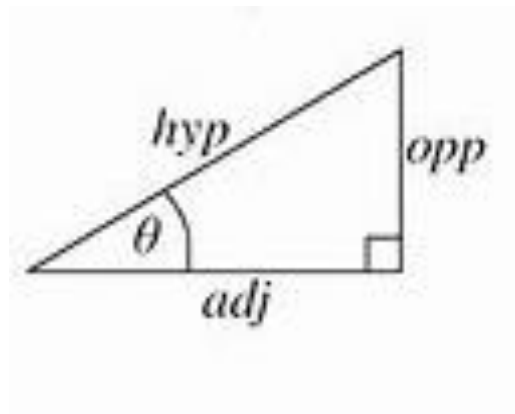

Trigonometric Ratios

$$\sin(\theta) = \frac{opp}{hyp}$$

$$\cos(\theta) = \frac{adj}{hyp}$$

$$\tan(\theta) = \frac{opp}{adj}$$

The basic idea of trigonometry is of course to be able to work out an unknown angle if you know two side lengths or an unknown side length if you know an angle and another side length. Remember as well to “undo” a trig function you need the inverse functions \sin^{-1} , \cos^{-1} , \tan^{-1} . The “-1” bit here does not mean “raised to the power of minus 1” as it normally would. It is just a long standing convention to notate the inverse trig functions in this way. Finally, the sine and cosine of an angle will always be less than one but the tangent of an angle can be any number.

You must always make sure your calculator is on the right setting when doing these calculations. There are two units to measure angles in that you will meet. One is the familiar “degrees” that you have been using at GCSE. An angle can run between 0° and 360° in this system. The other is a “radians” more on this in the next section. Many marks have been thrown away for simply not having the calculator in the correct mode when doing trigonometry. Be sure to check which it is you need in the question.

Let’s find the missing angle in the following right angled triangle.

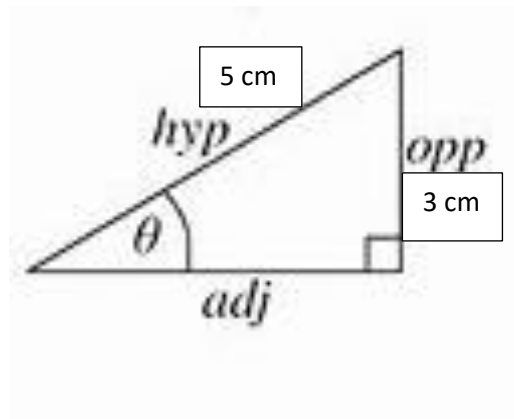

We are given the hypotenuse and the opposite side so we need the sine function.

$$\theta = \sin^{-1}\left(\frac{3}{5}\right) = 37^\circ$$

What about if we want to work out a missing side. Say, the opposite side in this one.

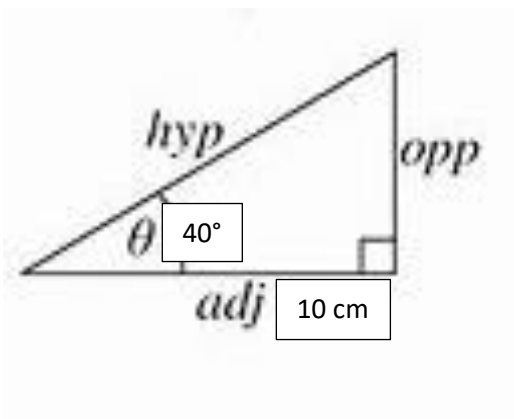

We are given the adjacent and we want the opposite so we need tan.

$$\tan 40^\circ = \frac{opp}{10}$$

Re-arranging.

$$opp = 10 \tan 40^\circ = 8.4 \text{ cm}$$

No for the extra bits. The most common extra formula you will need is the following trig identity.

$$\tan \theta = \frac{\sin \theta}{\cos \theta}$$

This is very useful for simplifying complicated looking equations so make sure you learn it. Finally here are some very useful but a little more complicated formulae. The beauty of these is that they apply to **any triangle** not just right angled triangle of the basic sin, cos and tan functions. The first one is called the “cosine rule” and the second the “sine rule”.

$$a^2 = b^2 + c^2 - 2bc \cos A$$

$$\frac{a}{\sin A} = \frac{b}{\sin B} = \frac{c}{\sin C}$$

The bad news is that you are not actually given these formulae in the data booklet for exams so you must learn them. **The first one, the identity, must be learnt.** It comes up fairly frequently. The two “rules” may prove useful if you get stuck but you can get away without using them in A-level physics.

Exercises

32. Show that $\tan 45^\circ$ gives the same answer as $\sin 45^\circ$ divided by $\cos 45^\circ$.
33. The hypotenuse of a right angled triangle is 45 cm long. The hypotenuse makes an angle of 60° with the adjacent side. Find the length of the adjacent side.
34. Find the length of the opposite side on the triangle in question 33.
35. In the following diagram $F = 50 \text{ N}$. Find F_x and F_y .

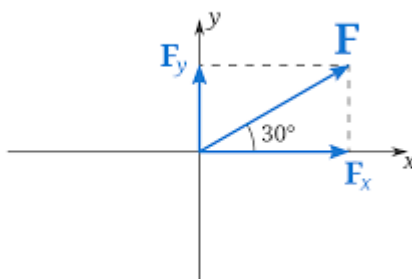

Radians

The most common way to measure an angle is to use degrees. It is totally arbitrary however. Why are there 360° in a circle? Because we say there are!

That doesn't mean it isn't extremely useful even though it is a made up system, but there is another system you need to learn for measuring angles called radians.

One radian is the angle made between two radii in a circle when the arc length between them is also the same distance as the radius.

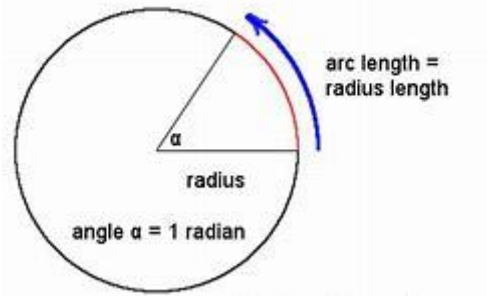

This may seem a strange way to measure angles but actually it is a lot more natural than using degrees. The above property is intrinsic in any circle you can ever draw after all. In addition to this **many theories in physics only work if the angles are measured in radians.**

Here are some useful formulae. The angle must be measured in radians remember.

$$\text{arc length} = \text{radius} \times \theta$$

What if the arc length is one whole circumference of the circle? We remember that the circumference is.

$$\text{circumference} = \pi d = 2\pi r$$

If we put $2\pi r$ as the arc length in to the arc length equation we get.

$$2\pi r = r\theta$$

Cancel the "r"s.

$$2\pi = \theta$$

So we see that there are 2π radians in a full circle. A similar procedure will show us that there are π radians in a half circle, and $\pi/2$ radians in a quarter circle. To convert quickly between the two use the following.

$$\frac{\text{radians}}{\pi} \times 180 = \text{degrees}$$

$$\frac{\text{degrees}}{180} \times \pi = \text{radians}$$

Here are some common angles to give you an idea of how they convert

degrees	0°	30°	45°	60°	90°	120°	135°	150°	180°
radians	0	$\frac{\pi}{6}$	$\frac{\pi}{4}$	$\frac{\pi}{3}$	$\frac{\pi}{2}$	$\frac{2\pi}{3}$	$\frac{3\pi}{4}$	$\frac{5\pi}{6}$	π

The final things to say about radians is that it is often ok to leave your answer as a multiple of π . It is more accurate this way and you will guess from the context of a question if you should leave your answer like this or write it out as a decimal. Next, radians are often used to describe cyclic processes because of their natural connection to circles. They come up a lot in waves for instance where we may wish to say what proportion of a full oscillation one point on a wave is separated from another. This will all become more clear when you begin to apply your knowledge of radians to real physical systems.

Exercises

36. How many degrees are in one radian? Express your answer as a decimal.
37. How many radians are in 60° ? Leave your answer as a multiple of π .
38. How many radians are in 270° ? Leave your answer as a multiple of π .
39. How many degrees are in $5\pi/4$ radians?
40. How many degrees are in $\pi/12$ radians?
41. How many radians do you think represent the gap between one entire wavelength on a wave?

Proportionality

The aim of many scientific experiments is to discover a cause and effect relationship between two variables. Let us take for example stretching a spring. So long as we don't stretch the spring too far the extension (how far it has stretched) goes up in even amounts when we add equal increments of force to it. We say that extension is directly proportional to the applied force.

$$\text{extension} \propto \text{applied force}$$

This sort of relationship will always give us a straight line graph. A very useful fact to remember when we wish to work out a quantity using experimental data (more on this later). For example here is the graph of weight and extension for the relationship mentioned above.

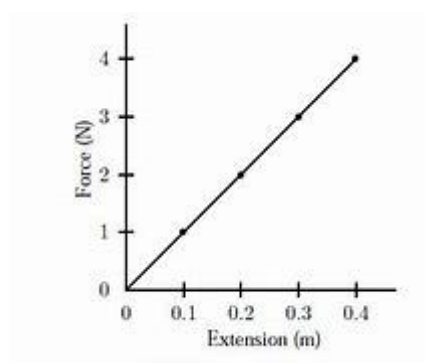

This is all very useful but we need to be able to actually get an equation to calculate one quantity when we know the other. We need to change a proportionality relationship into an equality. This is easier than it sounds. You just multiply by a constant "k". The above relationship therefore becomes.

$$F = ke$$

Some experimental data will allow us to work out the actual value of the constant and therefore any extension we like for any force we like. You might remember that the above constant is called the

spring constant in this experiment and is determined by the properties of the spring. Another example is found in electricity. For an ohmic conductor the potential difference across it is directly proportional to the current in the conductor.

$$P.D \propto \text{current}$$

$$V = kI$$

In this experiment the constant “k” turns out to be the resistance of the conductor. So we finally get.

$$V = IR$$

If one quantity, say y, **falls** as we raise another, say x, by even amounts we say they are inversely proportional.

$$y \propto \frac{1}{x}$$

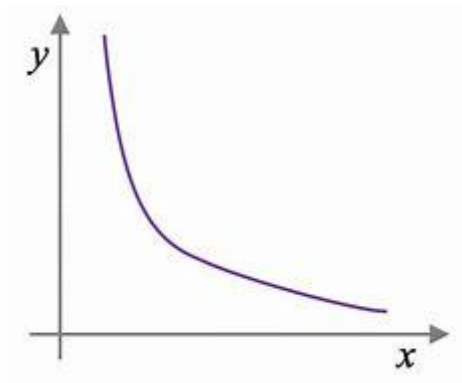

There are others. What if one quantity depends on a second variable **squared**.

$$y \propto x^2$$

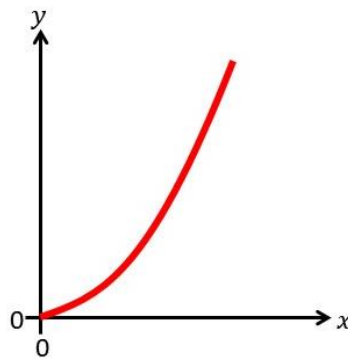

Or finally, as is the case in fields (gravitational, electric and magnetic), **inversely proportional to the second variable squared**.

$$y \propto \frac{1}{x^2}$$

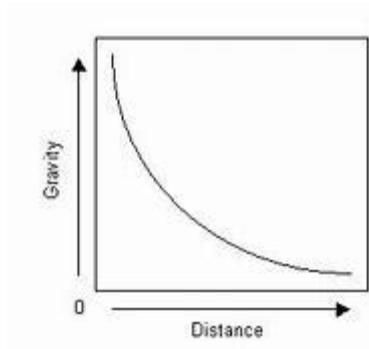

All of these proportional relationships, if they describe a real physical system, can be turned into equations by multiplying by a constant. Sometimes the constant is very simple, as in the case of the spring, at other times it is more complicated, as in the case of gravity.

Exercises

42. What is the constant that links the two directly proportional variables in the table below?

Seconds (x)	Feet (y)
4	10
8	20
12	30
16	40

Straight Line Graphs

You will hopefully remember that all straight line graphs can be written in the form.

$$y = mx + c$$

Where x and y are the two variables, m is the gradient and c is the y-intercept.

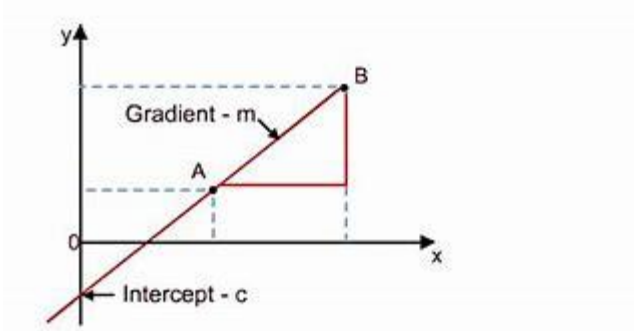

A lot of physical systems follow this pattern or can at least be re-arranged to follow this pattern. This allows us to work out various bits of information, often natural constants to do with systems by locating the y-intercept or working out the gradient of the graph and equating it to the equation that describes the system. Remember that the gradient can be positive or negative. A negative "m" represents a down-slope and a positive "m" an up-slope.

An example will help to illustrate this. This graph represents data from an experiment designed to work out the “internal resistance” of a power source. It is not important what this means right now, just try and follow the maths!

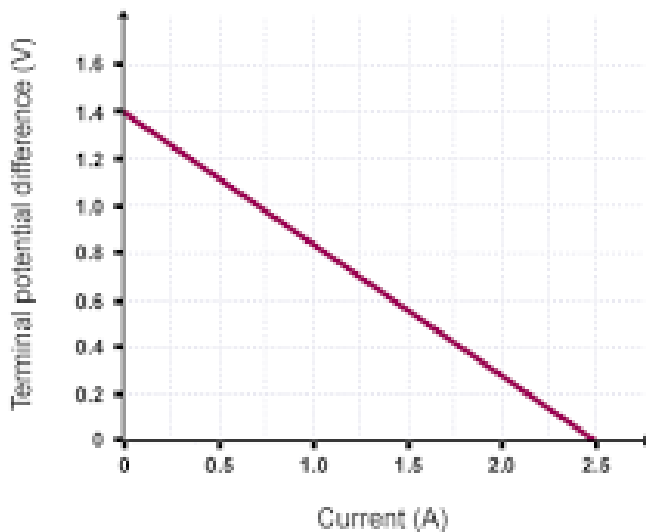

The equation that governs this graph is.

$$V = -RI + \epsilon$$

Where V is the potential difference, I is the current, R is the resistance and ϵ is the electromotive force. Don't worry exactly what this means physically right now, let's just match this up to the straight line graph equation and see what equated to what.

$$\begin{array}{c}
 y = mx + c \\
 \downarrow \quad \downarrow \quad \downarrow \\
 V = -RI + \epsilon
 \end{array}$$

So here the y axis represents the potential difference and the x-axis is the current. We knew this anyway as these were our variables in the experiment. But we can work out the two unknown constants using the graph. Firstly the gradient. Remember the gradient = change in y divided by change in x. We must take account of signs too. The change in y is $0 - 1.4 = -1.4$. The change in x is $2.5 - 0 = 2.5$. So the gradient is.

$$gradient = \frac{-1.4}{2.5} = -0.56 = -R$$

From this we can get that R equals 0.56 Ohms. What about the y-intercept? The graph crosses the y-axis at 1.4 V. so we can conclude that the electromotive force is 1.4 V.

This technique can be applied to many of the formulae that you'll meet, even ones that may not initially seem that they will obviously fit $y = mx + c$. We will learn some tricks in later sections to be able to twist and bend functions that look nothing like a straight line to fit these ideas so we can work out useful things.

Remember the gradient can be found by drawing a large triangle under the straight line graph and using the formula.

$$m = \frac{\text{change in } y}{\text{change in } x}$$

Exercises

43. You are given the following formula and are told to plot “v²” on the y-axis and “s” on the x-axis. What will be represented by the gradient and y-intercept on the graph?

$$v^2 = u^2 + 2as$$

44. What is the formula of this graph?

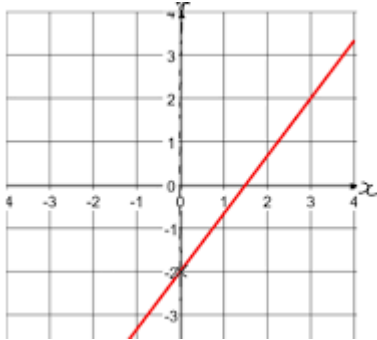

45. What is the formula of this graph?

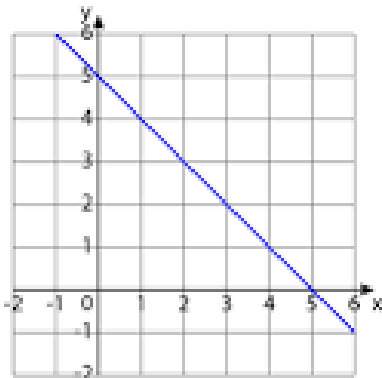

46. You are given the following formula. You wish to use a graph to work out the value of “m”. Suggest what you should plot on the x-axis and y-axis. What would the gradient be equal to? What about the y-intercept?

$$F = m\omega^2 r$$

Drawing a Tangent

Getting the gradient of a straight line is relatively straight forward. Sometimes however it is necessary to get the gradient on a point on a curve. The first problem is that the gradient constantly changes on a curve so the formula from the previous section falls down immediately.

If we know the equation of the curve you learn a method called “differentiation” to get a function that will give you the gradient at any point. This isn’t covered in A-level physics however so this is out too! There is only one option left. We need to draw a tangent.

This is a bit of an inexact science so you will get a little bit of leeway in the answer if you ever have to do it for real in an exam.

Let's say we have the following curve from some experimental data and we wish to know the gradient at the point $x = 3$. We draw a straight line that just touches the curve at the point where $x = 3$ trying to make sure that the gaps between the tangent and the curve are even before and after the point. The diagram below should help to clarify things.

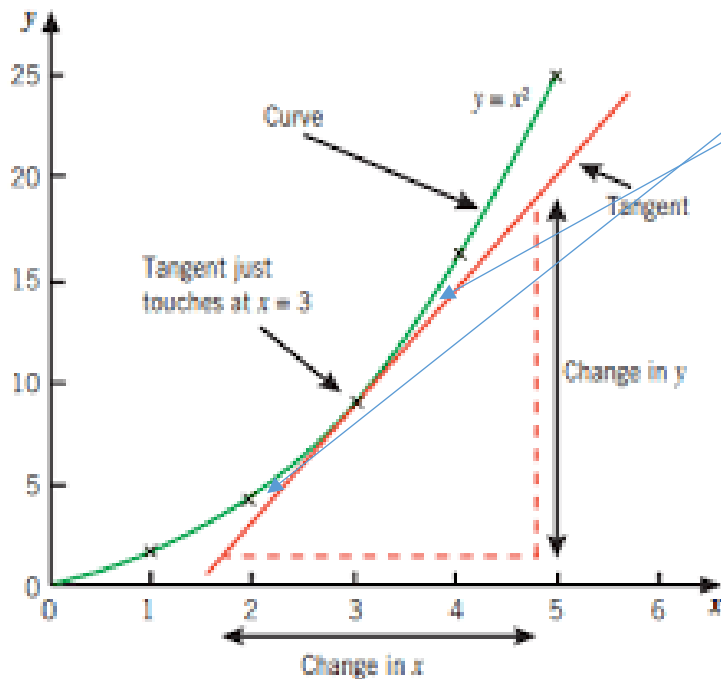

We then calculate the gradient of the tangent just like we did with straight line graphs in the previous section.

$$m = \frac{\text{change in } y}{\text{change in } x}$$

Remember that this whole process gives us only the gradient at this single point only. If we wanted the gradient at a different point we would have to start the whole process again at that point.

This technique comes in handy when trying to work out velocities and accelerations from curved motion graphs.

Exercises

47. Draw a tangent on the graph below to work out the gradient at time = 50 seconds (in this case you will be working out the velocity of the object at this point).

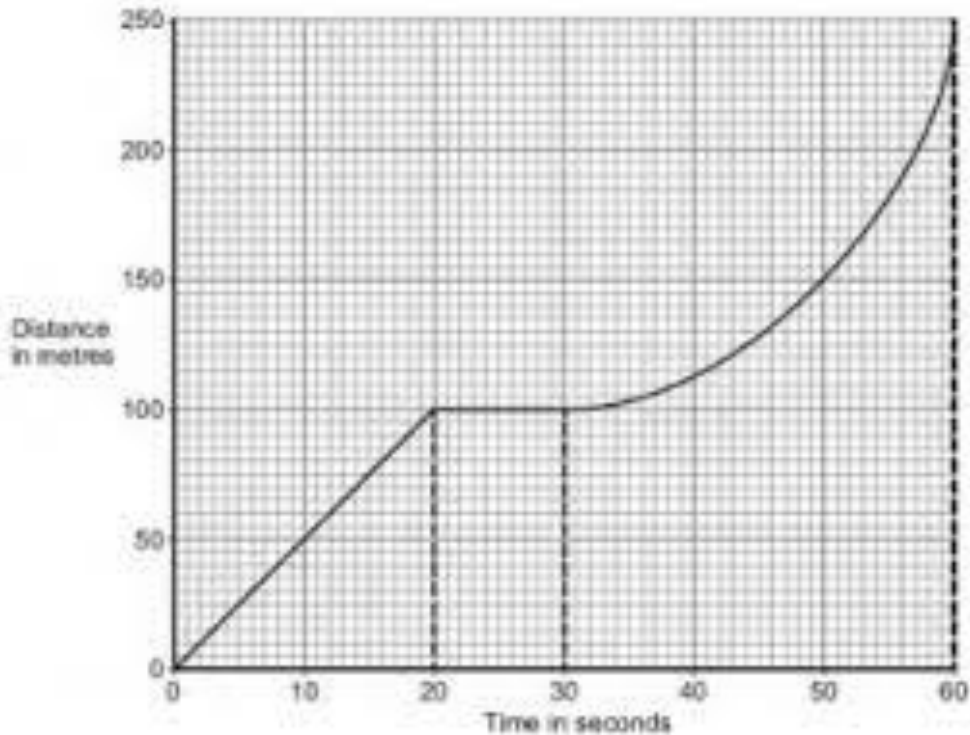

Areas Under Graphs

This is another area where you will likely already be confident. The technique is to break the area under the graph into easy geometric shapes as best you can, work out the area of each individually then add them all up.

Aim to make rectangles, squares, triangles and parallelograms.

$$\text{area of square} = \text{area of rectangle} = \text{base} \times \text{height}$$

$$\text{area of triangle} = \frac{1}{2}(\text{base} \times \text{height})$$

$$\text{area of parallelogram} = \left(\frac{1}{2}(\text{left side} \times \text{right side}) \right) \times \text{height}$$

The complication comes when trying to get the area under a curve. Just like getting the gradient there is a technique you learn in A-level maths called integration that will give you an exact answer (so long as you know the equation of the line). We don't cover this at A-level physics though so you quite simply have to count squares! This means trying to estimate a total amount of squares, adding up half squares etc as you go. This is inexact so you get some leeway in the answer.

Let's look at the graph from the last section and see if we can work out the area underneath the line.

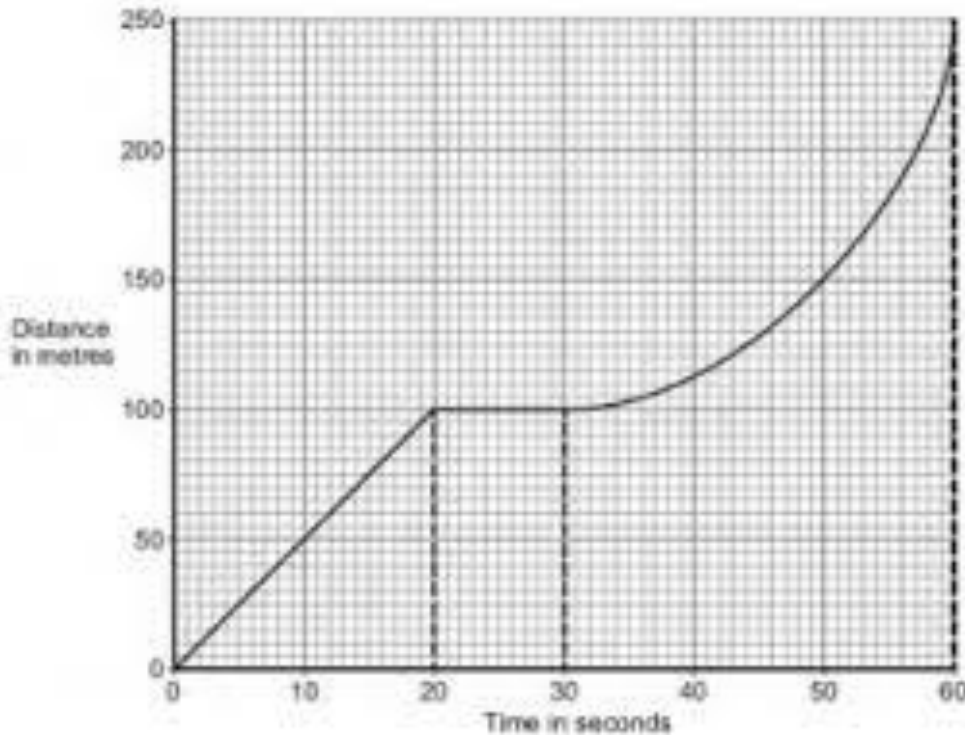

The first section is a triangle running between 0 and 20 seconds with a height of 100 m.

$$area = \frac{1}{2}(20 \times 100) = 1000$$

The second section is a rectangle. The base is 10 seconds long and the height is 100 m again.

$$area = 10 \times 100 = 1000$$

The final section is the tricky bit. We are going to try and estimate the number of big squares under the curve. There are 7 whole squares and then about one and a half squares just under the curve. A total of 8.5 squares. The area of one big square is $10 \times 50 = 500$. So:

$$area \text{ of curved section} = 8.5 \times 500 = 4250$$

Finally we add them all up.

$$total \text{ area} = 1000 + 1000 + 4250 = 6250$$

Simple. You may be disappointed to find out that the area you just worked out has no physical meaning it was just for practice! Lots of graphs do have a particular meaning though. For instance the area under a velocity-time graph gives you displacement or the area under a force-time graph gives you impulse.

Exercises

48. Work out the area under the graph below. In doing so you will work out the displacement of the object that traced out that graph.

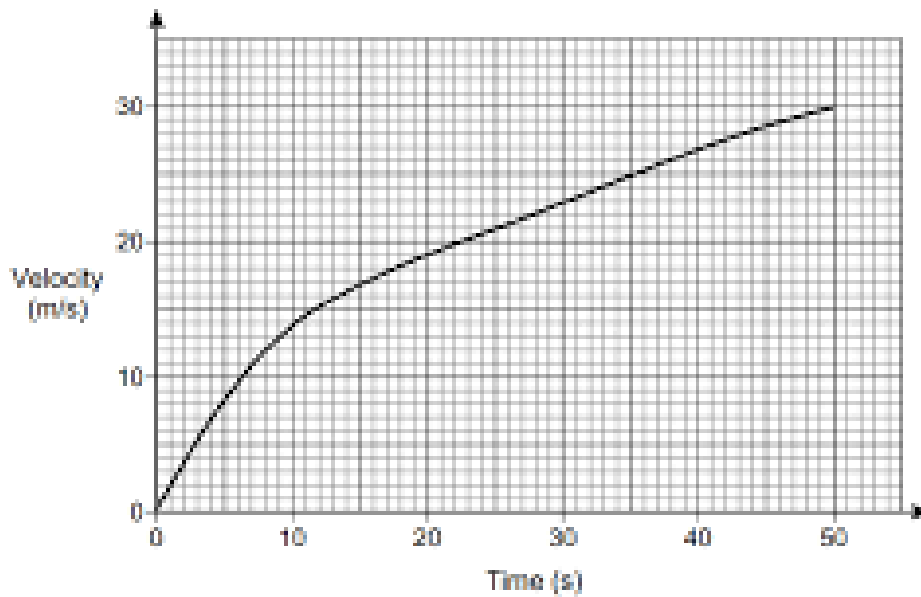

Simultaneous Equations

The normal rules of algebra state that to solve an equation for one unknown you need 1 equation containing that unknown. For example.

$$x + 2 = 5$$

Obviously gives.

$$x = 3$$

This one though contains two variables and is impossible to solve as it stands.

$$x + y = 5$$

There are an infinite amount of combinations of x and y that could fit this equation and this is often no good to a scientist. We need unique values for x and y . The rules of algebra state that however many unknowns you have you need the same amount of equations in order to solve for unique values. Let's add another equation in which x and y have the same (as yet unknown) values as the above equation but are in a different combination.

$$x + y = 5$$

$$x - y = 1$$

This is now solvable in two ways. We could eliminate one of the variables by adding or subtracting multiples of the equations. Or we could make x or y the subject of one of the equations and substitute it into the other one.

By elimination we add the equations together to get rid of "y"

$$x + y + x - y = 5 + 1$$

$$2x = 6$$

$$x = 3$$

By the second method we will make y the subject of the second equation.

$$x - 1 = y$$

Then substitute in for y in the first equation.

$$x + x - 1 = 5$$

$$2x = 6$$

$$x = 6$$

Same answer! So it doesn't matter how you did it. It is either a matter for personal taste or if one method suits a particular situation better than another. Experience will be your guide here.

We can also combine together equations in a similar way even if we don't want a particular solution to an equation but instead want to combine algebraic formulae to find an expression for a particular quantity. For example let's say we have the following two expressions for force.....

$$F = \frac{GMm}{r^2}$$

$$F = \frac{mv^2}{r}$$

...and we want an expression for " v " that does not include " F ". Since the two equations both equal the same thing we can make the two equations equal to each other and eliminate " F ". We then use the normal rules of algebra to solve for " v ".

$$\frac{GMm}{r^2} = \frac{mv^2}{r}$$

We divide both sides by " m " and multiply by r^2 .

$$GM = rv^2$$

Then divide by " r " and square root both sides to give.

$$v = \sqrt{\frac{GM}{r}}$$

Lots of practice is needed to be able to do this quickly. Luckily you will get plenty of it during A-level physics!

Exercises

49. Solve the simultaneous equations

$$2x + 3y = 16$$

$$5x - y = 6$$

50. Solve the simultaneous equations

$$x^2 + y = 10$$

$$x + y = 4$$

51. Given the following two equations eliminate " u " and re-arrange to get an expression for s that therefore doesn't contain " u "

$$a = \frac{v - u}{t}$$

$$s = ut + \frac{1}{2}at^2$$

The Quadratic Formula

A quadratic equation is one that looks like this.

$$y = ax^2 + bx + c$$

The quadratic bit refers to the fact that the highest power of “x” in the equation is a squared. A, b and c are any constants. They come up a lot in physics in general for instance this formula for constantly accelerated motion is a quadratic formula with “t” instead of “x”, “s” instead of “y”, “u” instead of “b” and “1/2 a” instead of “a”.

$$s = ut + \frac{1}{2}at^2$$

Quadratic equations can be solved explicitly in one of two ways. If we are lucky the equation will factorise and we get a quick, neat answer. Often though they will not factorise and we can use a formula to solve explicitly for “x” (or whatever is standing in for x).

$$x = \frac{-b \pm \sqrt{b^2 - 4ac}}{2a}$$

Notice the \pm sign. This means we will get 2 different answers for “x”. Usually the context of the question will strongly hint that one answer is correct and one does not fit the situation.

Another possibility is that the bit underneath the square root sign equals zero and so disappears. This means we get only one answer for “x” (strictly speaking it is in fact the same answer repeated) and so we remove any ambiguity as to the answer we need for the question.

The final possibility is that the bit underneath the square root gives a negative number and we are left with the square root of a negative number. This is still solvable but instead you get a “complex conjugate” pair of answers that contain a real and imaginary part. You won’t meet these in A-level physics.

Whilst this formula is relatively rarely used in A-level physics it comes up now and again so you should be confident in using it. As always lots of practice is the best way.

Exercises

52. Rewrite the quadratic formula using the following equation as your starting point.

$$s = ut + \frac{1}{2}at^2$$

53. Solve for “x”: $x^2 + 3x + 2$

54. Solve for “t”: $2x^2 + 4x + 1$

Logs and Exponentials

Nearly there.

Take the equation.

$$10^x = 150$$

How can we find “x”? We must do the inverse (opposite) of raising to a power. Raising to a power is called “exponentiation” and the inverse function is called “taking a logarithm”. So we need a new function.

$$\log_{10} y = x$$

Means the number you must raise 10 to the power of to get the answer y. So in our example above we could write.

$$\log_{10} 150 = 2.18$$

Here we say that the logarithm is in “base 10” as 10 is the number we are raising to a power. We have to use a calculator to get this answer. Make sure you know where the logarithm button is on your calculator. The last equation above shows us finally that.

$$10^{2.17} = 150$$

All very useful. In physics however we don’t tend to use “base 10”. We tend to use a different base. We use the number 2.718281828..... This number gets the symbol lower case “e”.

This may seem a strange choice but is chosen because this number differentiates to itself and so considerably simplified several more advanced techniques (you don’t need to know this for A-level physics). In addition instead of writing “log” we now write “ln” which means “natural logarithm”. The natural refers to the “natural convenience of the number “e”. So the equivalent of the “base 10” formulae above are.

$$e^x = y$$

$$\ln y = x$$

Let’s try an example of using these functions. We want to find “x” in.

$$e^x = 10$$

$$\ln 10 = x = 2.3$$

We can also combine natural logarithms in ways that you will use fairly frequently in the later topics in A-level physics. Learn these.

$$\ln ab = \ln a + \ln b$$

$$\ln \frac{a}{b} = \ln a - \ln b$$

$$\ln a^b = b \ln a$$

$$\ln e^x = x$$

$$e^{\ln x} = x$$

You will remember from the straight line graphs section that we said you could use some trickery to make seemingly far out equations fit $y = mx + c$. Well, the above “log laws” are the necessary trickery. They have the effect of taking an exponential relationship and turning it in to linear one. Let’s take a look. Say we get the equation.

$$a = be^{cd}$$

Take the natural logarithms of both sides.

$$\ln a = \ln b e^{cd}$$

The right hand side is a case of the first log law. It is two different parts multiplied together so we can split it.

$$\ln a = \ln b + \ln e^{cd}$$

The fourth log law from above means the final part of our equation simplifies.

$$\ln a = \ln b + cd$$

This is now in the same form as $y = mx + c$. We have.

$$\ln a = y$$

$$c = m$$

$$d = x$$

$$\ln b = c$$

So a plot of “d” on the x-axis and “ln(a)” on the y-axis should give a straight line of gradient “d” and y-intercept “ln(b)”. Magic.

This may seem complex and you will very likely not have seen it in GCSE maths. Keep practicing and come and find help if you need any more explanation and more practice.

Exercises

55. Solve for x. $e^x = 2$

56. Solve for x. $\ln x = 5$

57. Simplify. $\ln a + 2 \ln b$

58. Re-arrange the following equation in to the form $y = mx + c$. $A = A_0 e^{-\omega t}$

You made it! Be sure to keep up the practice and keep asking for help if needs be.

Answers

1. 16
2. 0.04
3. 1.84
4. 8
5. 0.125
6. a^{10}
7. z^4
8. $y^{0.25}$
9. 2×10^3
10. 2.5×10^3
11. 2×10^{-4}
12. 2.5×10^{-4}
13. 100000
14. 156000
15. 0.00001
16. 0.0000156
17. 1.5 km
18. 12 kg
19. 6000 mm
20. 0.000006 g
21. 7.88×10^{-11}
22. No
23. Yes
24. 600 μm
25. $B = \frac{F}{IL}$
26. $m_1 = \frac{Fr^2}{Gm_2}$
27. $r = \sqrt{\frac{Gm_1m_2}{F}}$
28. $v = c \sqrt{1 - \left(\frac{t_0}{t}\right)^2}$
29. $b = \sqrt{a^2 - c^2}$ $c = \sqrt{a^2 - b^2}$
30. 36 cm
31. 300 N
32. $\tan 45^\circ = 1 \frac{\sin 45^\circ}{\cos 45^\circ} = 1$
33. $45 \cos 60^\circ = 22.5$
34. $45 \sin 60^\circ = 39$
35. 43.3 N, 25 N
36. 57.3°
37. $\pi/3$
38. $3\pi/2$
39. 225°
40. 15°
41. 2π
42. $K = 2.5$ feet/second

43. Gradient = $2a$, y-intercept = u^2
 44. $y = (4/3)x - 2$
 45. $y = -x + 5$
 46. y-axis = F , x-axis = r , gradient = $m\omega^2$, y-intercept = 0
 47.

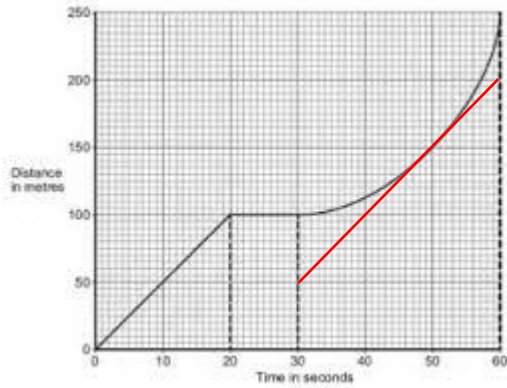

Gradient of tangent = 5 m/s

48. 950 – 1050 m
 49. $x = 2, y = 4$
 50. $x = 3, y = 1$
 51. $s = vt - \frac{1}{2}at^2$
 52. $t = \frac{-u \pm \sqrt{u^2 - 2a}}$
 53. $x = 1, x = 2$
 54. $x = -0.13, x = -1.37$
 55. $x = 0.693$
 56. $x = 148.41$
 57. $\ln ab^2$
 58. $\ln A = \ln A_0 - \omega t$